

Gebrauchsanleitung  
Installation and Operating Instructions  
Notice de montage et d'installation



RENO ELEMENTS



2020/09/A



.hess



Wichtige Hinweise  
Important Information  
Consignes importantes



**(D)** Montage- und Wartungsarbeiten sind nur mit Originalteilen durchzuführen. Für die Installation und den Betrieb sind die nationalen und internationalen Vorschriften zu beachten. Werden nachträglich Änderungen an Leuchten vorgenommen, so gilt derjenige als Hersteller, der diese Änderungen vornimmt. Hess Licht + Form übernimmt keine Haftung für Schäden, die durch unsachgemäßen Einsatz entstehen. Montage nur durch Fachpersonal.

**(GB)** Only use original parts for maintenance and installation of this luminaire. National and international regulations and laws apply to the installation and operation of this lighting fixture. If modifications are made to the luminaire, the party who made the modifications shall be considered the legal manufacturer thereafter. Hess Licht + Form does not accept liability for any damages that occur due to improper or unskilled actions. Only qualified persons are permitted to install and assemble products obtained from Hess Licht + Form.

**(F)** Tous travaux de montage et d'entretien ne doivent être effectués qu'avec des pièces d'origine. Observez les consignes de sécurité électriques nationales et internationales lors de l'installation et lors du fonctionnement. En cas de modifications ultérieurement apportées aux luminaires, la personne responsable de ces modifications est considérée comme le fabricant. Hess Licht + Form n'assume aucune responsabilité pour les dommages résultant d'une utilisation non conforme. Le montage ne doit être effectué que par des spécialistes.



**(D)** ACHTUNG! Die Montage /Wartung der Reno Elemente darf nur bei trockener Witterung durchgeführt werden. Es dürfen keine feuchten Komponenten eingebaut werden.

**(GB)** CAUTION! The installation / maintenance of the Reno elements may only be carried out in dry weather. Never install components if they are damp.

**(F)** ATTENTION ! Le montage ( maintenance ) des colonnes lumineuses Reno Elements ne peut se faire que par temps sec. Aucun composant humide ne peut être monté.



**(D)** ACHTUNG! Zerstörungsgefahr! Chemikalien und Materialien mit korrodierenden Wirkungen dürfen nicht auf die Leuchte einwirken. Schrauben leicht fetten.

**(GB)** CAUTION! Damage may occur! Do not allow chemicals or other corrosive materials to come in contact with the luminaire. Apply a little grease to the screws.

**(F)** ATTENTION ! Risque de destruction ! Ni produits chimiques ni matières à effet corrosif ne doivent pouvoir agir sur le luminaire. Graisser légèrement les vis.



**(D)** Bei Wartungsarbeiten und beim Lampenwechsel muß das Element spannungsfrei sein. Es muß Schutzkleidung getragen werden.

**(GB)** When performing maintenance and changing the lamp, always make sure that the power is off in the luminaire (entire column). Protective clothing must be worn.

**(F)** Lors de tous travaux d'entretien et lors du remplacement d'une source lumineuse, il faut absolument mettre le module hors circuit. Il faut absolument porter un vêtement protecteur.



**(D)** Zur Vermeidung von Gefährdungen darf eine beschädigte äußere flexible Leitung dieser Leuchte ausschließlich vom Hersteller, seinem Servicevertreter oder einer vergleichbaren Fachkraft ausgetauscht werden.

**(GB)** To avoid hazards, a damaged outer flexible cable of this lamp may only be replaced by the manufacturer, his service representative or a comparable specialist.

**(F)** Pour éviter tout danger, un câble flexible extérieur endommagé de cette lampe ne peut être remplacé que par le fabricant, son représentant de service ou un spécialiste comparable.

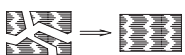

**(D)** Die Leuchte darf nur mit kompletter Schutzabdeckung betrieben werden.

**(GB)** Only operate this luminaire when it is in a closed state, i.e. with closed cover.

**(F)** Ne faire fonctionner le luminaire qu'avec le couvercle de protection fermé.

**(D)** Es dürfen nur die vom Leuchtenhersteller vorgeschriebenen Ersatzteile eingesetzt werden. Die Vorschriften der Lampenhersteller sind zu beachten.

**(GB)** Only replacement parts specified by the lighting fixture manufacturer may be used. In addition, the lamp manufacturer's instructions must be followed.

**(F)** Seules les pièces de rechange prévues par le fabricant des luminaires doivent être utilisées. Observez les consignes du fabricant de lampes.



**(D)** Die Lichtquelle dieser Leuchte darf nur vom Hersteller oder einem von ihm beauftragten Servicetechniker oder einer vergleichbar qualifizierten Person ersetzt werden.“

**(GB)** The light source of this lamp may only be replaced by the manufacturer or a service technician commissioned by him or a comparable qualified person.

**(F)** La source lumineuse de cette lampe ne peut être remplacée que par le fabricant ou un technicien de service mandaté par lui ou par une personne qualifiée comparable.



**(D)** Empfehlung Einbau Bewegungsfuge.  
Wir empfehlen ein elastisches Fugendichtsystem zwischen Mast und Oberflächenbelag zu verwenden um Beschädigungen am Mast durch Belagsbewegungen oder durch Schwingungen des Mastes zu vermeiden.

Ausgelegt nach Merkblatt M FPgeb R2 Baugrundsätze und Ausführungen von Bewegungsfugen nach Abs.4.10 und 6.5 der FGSV Forschungsgesellschaft für Straßen- und Verkehrswesen.

**(GB)** Recommendation for fitting of movement joint.  
We recommend an elastic joint sealing system between mast and surface layer, in order to prevent damage caused by surface layer deformation and vibration of the mast.

Designed according to leaflet M FPgeb R2 building principles and execution of expansion joints according to paragraphs 4.10 and 6.5 of the FGSV Research Association for Roads and Transport.

**(F)** Joint de dilatation recommandé.  
Recommandation pour l'installation de joints de mouvement.  
Nous recommandons un joint élastique système d'étanchéité entre le mât et la surface  
Utilisez le platelage pour éviter d'endommager le mât par les mouvements du platelage ou par les vibrations du mât.

Conçu selon les principes de construction de la brochure M FPgeb R2 et exécution des joints de dilatation selon les paragraphes 4.10 et 6.5 de l'Association de recherche FGSV pour les routes et les transports.

**(D)** Vorbereitende Arbeiten zum Aufstellen des Mastes entnehmen Sie bitte der separaten Empfehlung.

**(GB)** Please refer to the separate recommendation for preparatory work for erecting the pole.

**(F)** Concernant les travaux préliminaires pour l'installation du mât merci de consulter la recommandation ci-jointe.

**(D)**



**(GB)**



**(F)**



**(D)** PMMA Reinigung  
Leuchtenabdeckungen aus PMMA-Kunststoff dürfen nur mit Wasser und Spülmittel, bei starken Verschmutzungen mit Waschbenzin gereinigt werden. Andere Mittel sind nicht erlaubt, insbesondere die Verwendung von alkoholhaltigen Reinigern (Spiritus, Glasreiniger, etc.) oder Kaltreinigern führen zur Beschädigung der Oberfläche.

**(GB)** PMMA cleaning instructions  
Only use a mild detergent and water to clean luminaire covers and enclosures of PMMA plastic. If the PMMA is very heavily soiled, you may use benzene, but with great care and sparingly. Do not use any other agents; in particular, alcohol-containing cleaners (spirits, glass cleaner, etc.) or cold cleaning solvents will damage the surface of the PMMA.

**(F)** Conseil de nettoyage  
Les couvercles de luminaire en matière plastique (de verre acrylique) sont à nettoyer exclusivement avec de l'eau et un produit vaisselle, l'éther de pétrole est autorisé en cas d'encrassements tenaces. Tout autre produit est proscrié, notamment l'emploi de détergents contenant de l'alcool (white-spirit, produits pour vitres, etc.) ou de détergents à froid qui endommageraient la surface.



**(D)** LED-Modul: Risikogruppe 2, nicht in den Strahl blicken!  
Die Leuchte ist so zu positionieren, dass längeres in die Leuchte schauen in einem geringeren Abstand als 0,4m nicht zu erwarten ist.

**(GB)** LED module risk group 2, do not look into the beam!  
Position the luminaire to avoid extended viewing into the luminaire at a distance of less than 0,4m.

**(F)** Module LED, groupe des risques 2, ne pas regarder le rayon.  
Positionnez le luminaire afin d'éviter d'y regarder longtemps à une distance inférieure à 0,4m.



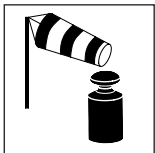
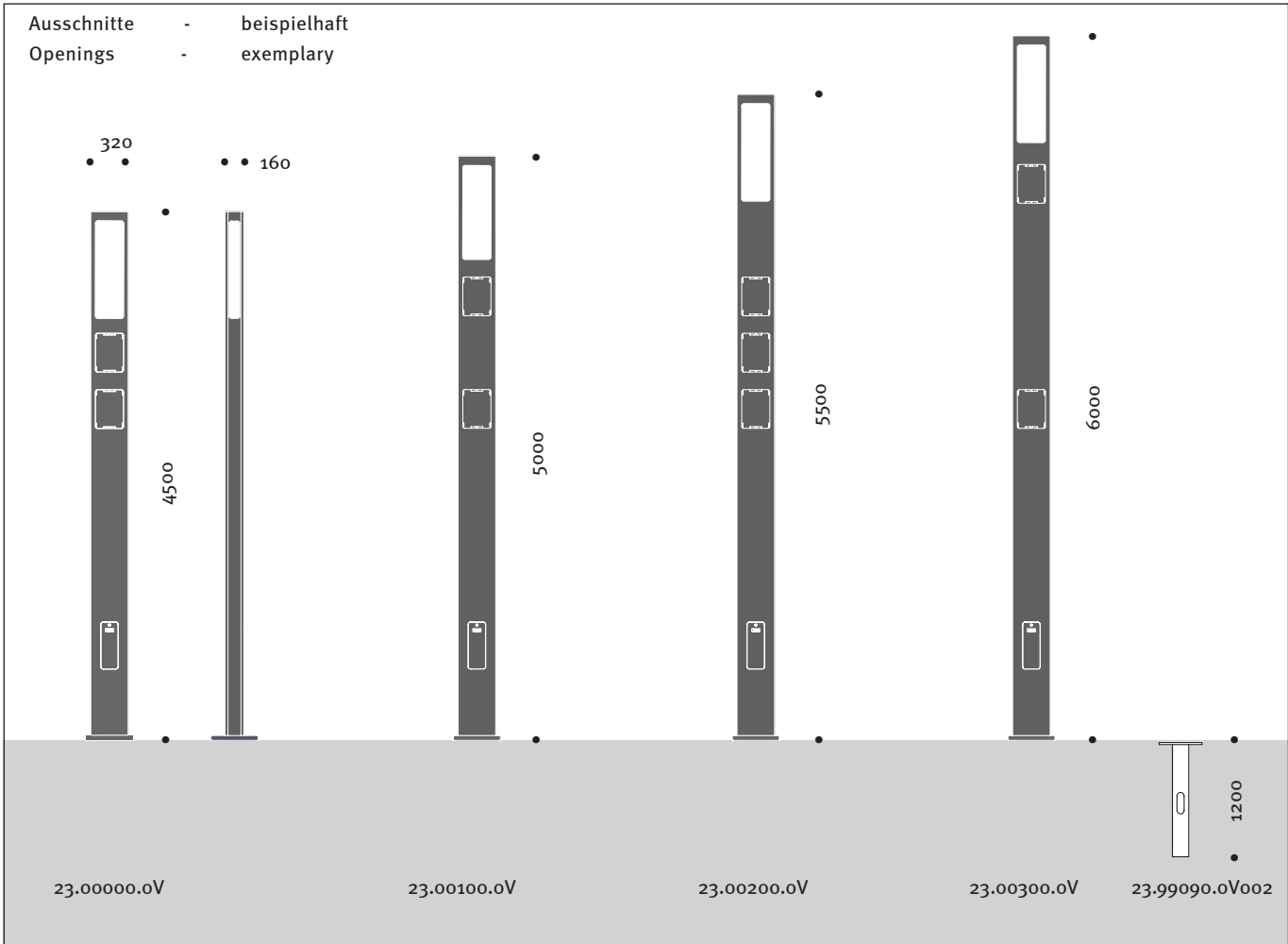

Lieferumfang  
Included in Luminaire Purchase  
Matériel fourni

RENO ELEMENTS	4500	5000	5500	6000
	mm	mm	mm	mm
	23.00000.oV	23.00100.oV	23.00200.oV	23.00300.oV



Gewichte / Windangriffsflächen  
Weight / Wind Catching Surface  
Poids / Surface de résistance au vent

Typ	Artikel-Nr.	 kg	 m <sup>2</sup>
RENO ELEMENTS 4500	23.00000.oV	81- 83	1,44
5000	23.00100.oV	88- 91	1,6
5500	23.00200.oV	95- 99	1,76
6000	23.00300.oV	102-107	1,92



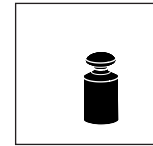

Lieferumfang  
Included in Luminaire Purchase  
Matériel fourni



Gewichte  
Weight  
Poids

RENO ELEMENTS

			
			kg
TOP LIGHT	23.10901.oV	23.11001.oV	10
SPOT LIGHT	23.11101.oV		4,8
CCTV	23.11104.oV		4,5
SPEAKER	23.11103.oV		4,5
COVER	23.99091.oV		0,9

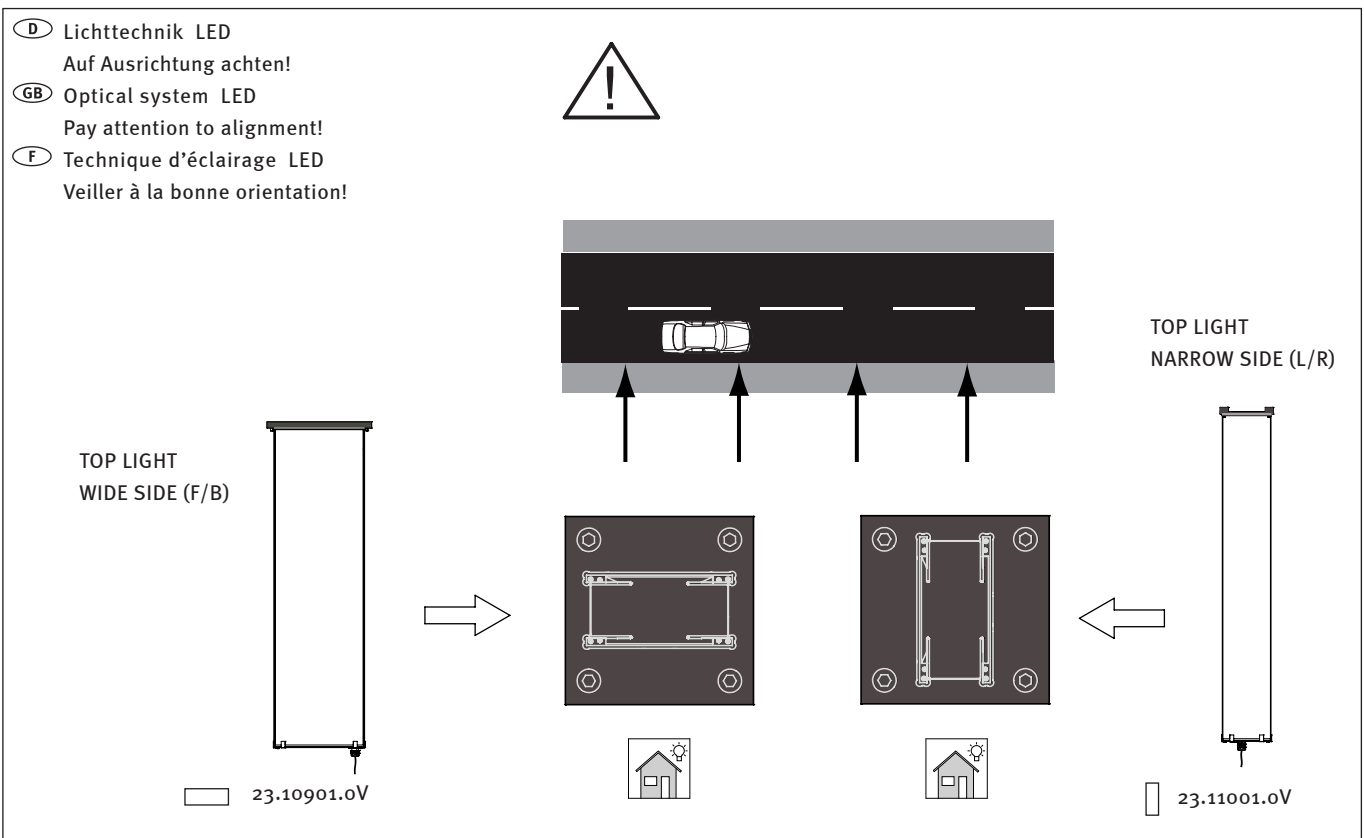
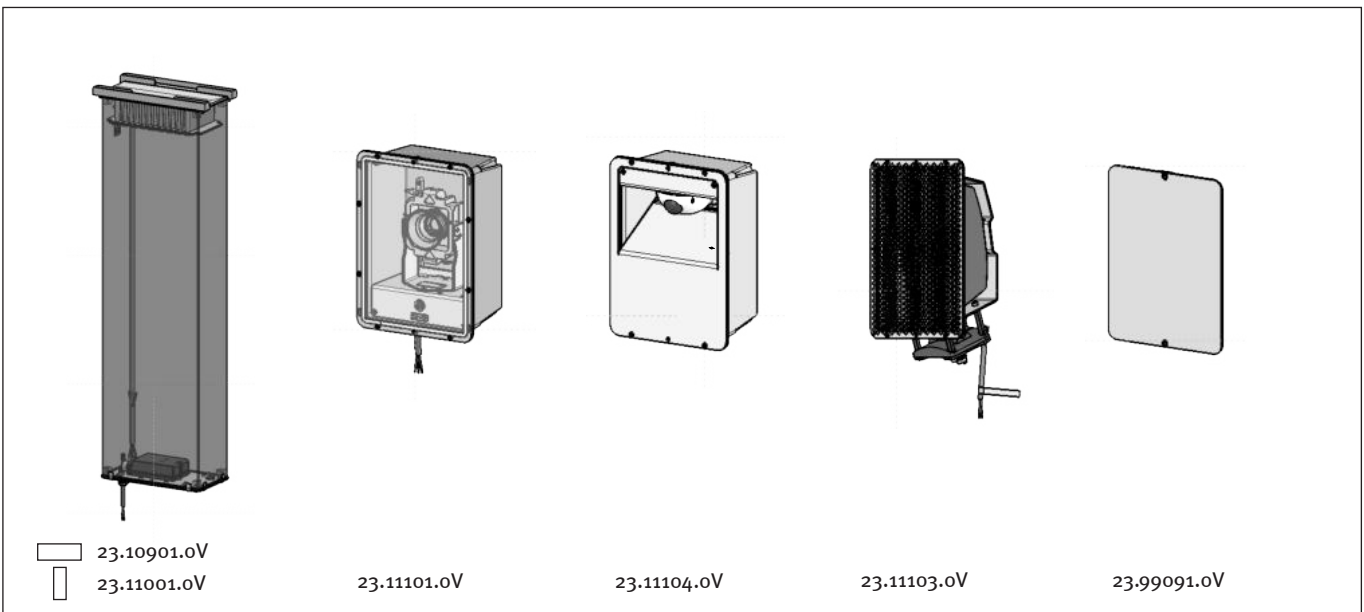



Empfohlene Montagefolge  
Recommended Installation Procedure  
Déroulement de montage recommandé

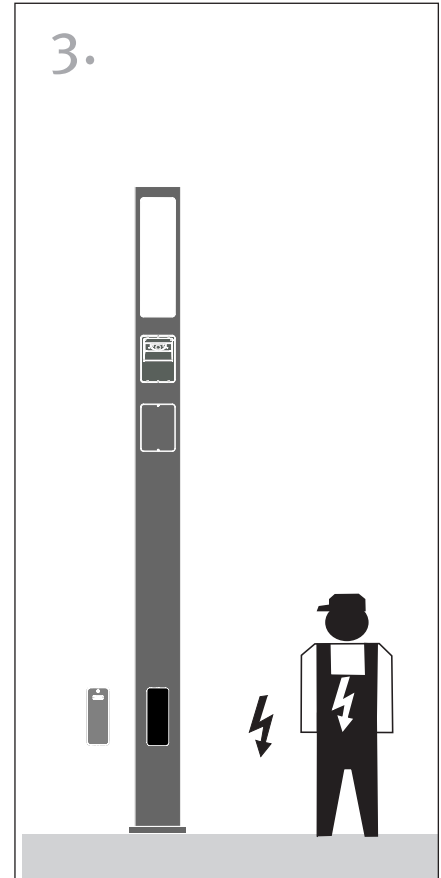
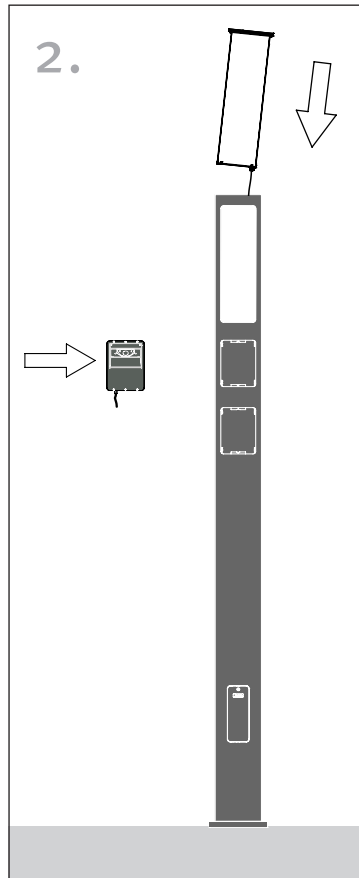
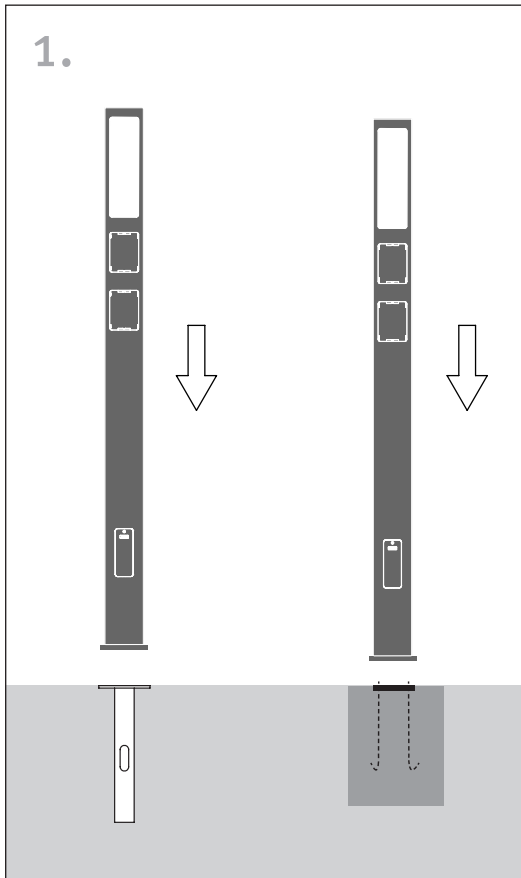

4.

- (D)** Kabelbelegung
- (GB)** Wiring diagram
- (F)** Positionnement brins de câble

5.

- (D)** Einstellmöglichkeiten "DIM Modul"
- (GB)** Settings "DIM Modul"
- (F)** Possibilités de réglage du "Module DIM"

6.

- (D)** Wartung / Nachrüsten
- (GB)** Maintenance / Retrofitting
- (F)** Entretien / Rééquipement

7.

- (D)** Dickschichtlackierung
- (GB)** extra thick coat of varnish
- (F)** laquage à couche épaisse

8.

- (D)** Einbauempfehlung Bewegungsfuge.
- (GB)** Recommendation expansion joint.
- (F)** Joint de dilatation recommandé.

**!**

- (D)** Die Grundelemente haben keinen eigenen IP Schutz. Bei kundenseitigen Sondereinbauten ist darauf zu achten, dass die jeweiligen eingebauten Komponenten einen eigenen IP Schutz aufweisen. Eine Drainage im Erdbereich ist zwingend vorzusehen.
- (GB)** The base elements do not have their own IP protection. For on-site installed components it must be ensured that the installed components have their own IP protection. Make sure that the base elements have drainage into the ground.
- (F)** Les éléments de base n'ont pas de protection IP propre. Pour les composants installés sur place il faut s'assurer que ces composants ont leur protection IP propre. Un drainage dans le sol est obligatoire.

1.

Mast aufstellen  
Putting Up the Pole  
Ériger le mât

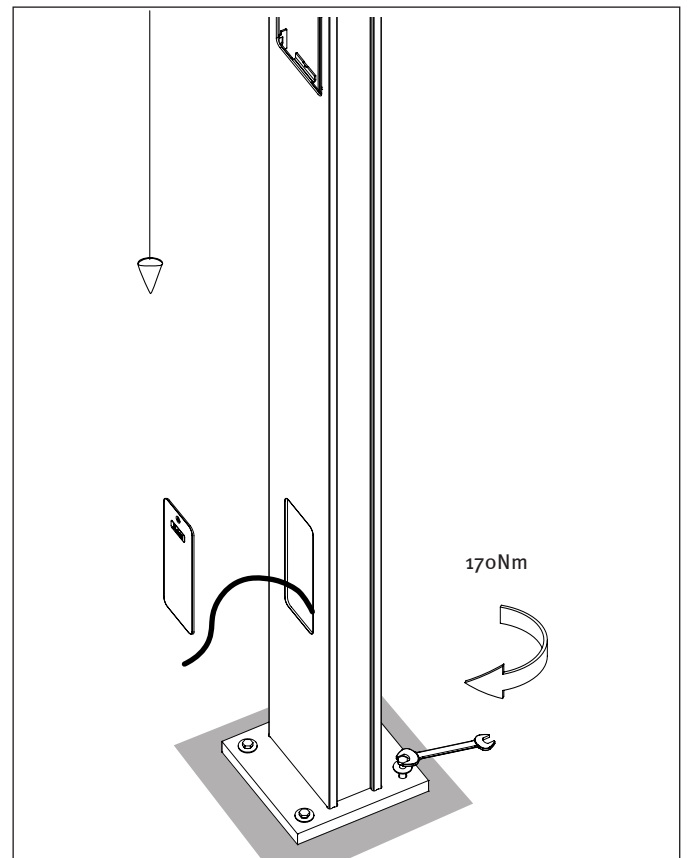
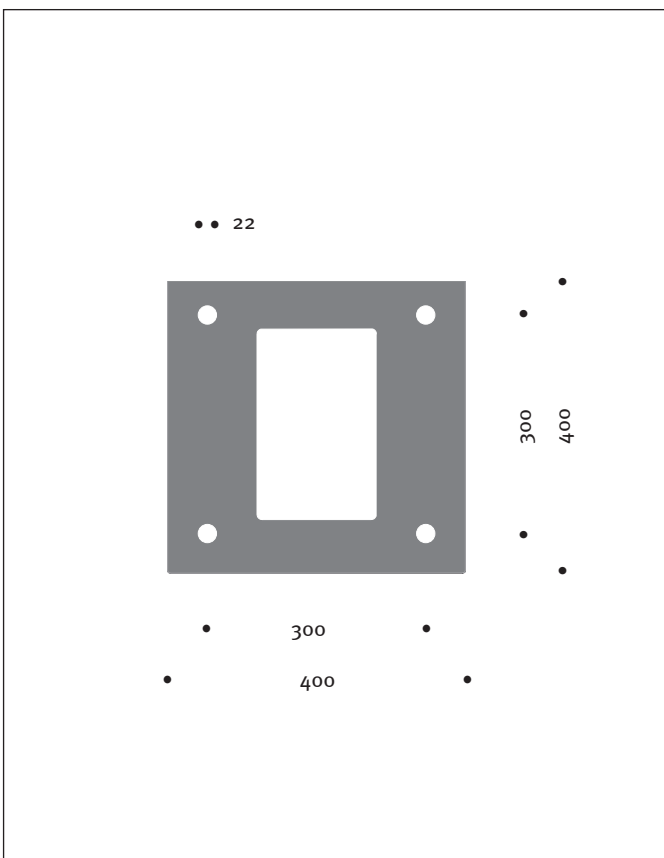
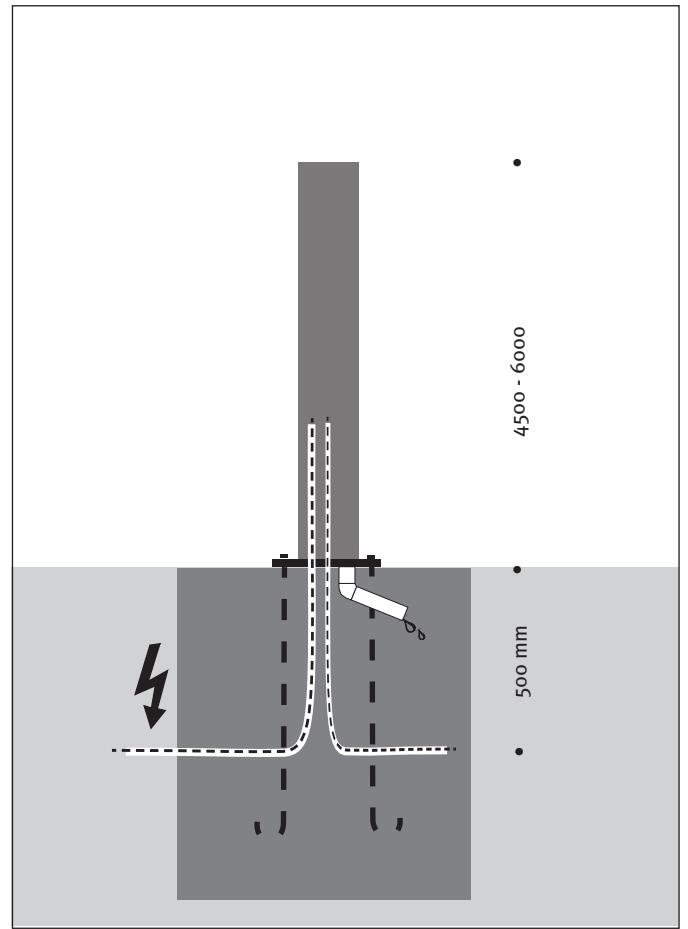
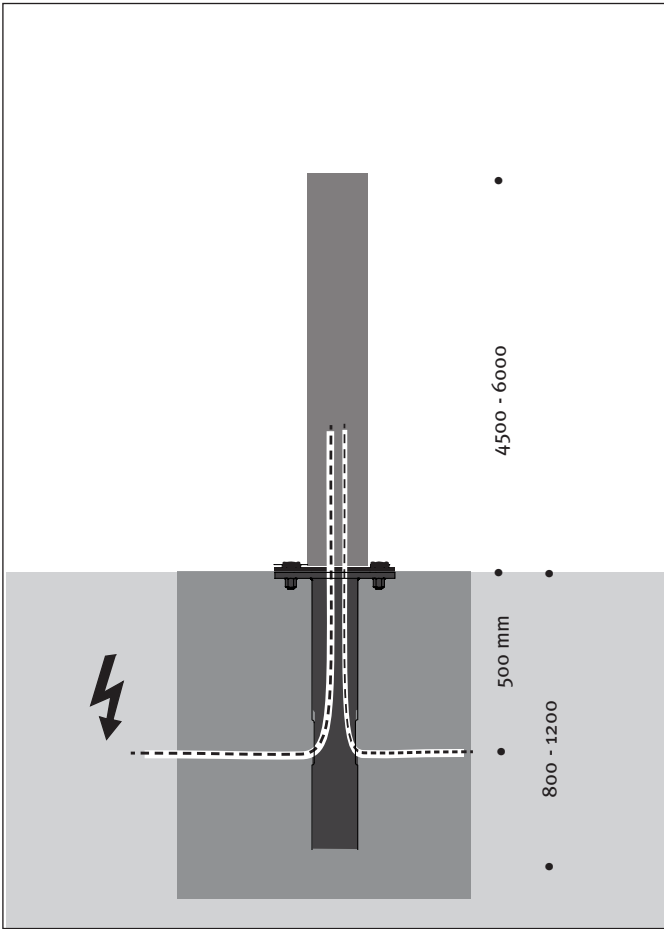

# 2.

Montage  
Mounting  
Montage



## 2.1 TOP LIGHT

- Ⓓ Schutzfolie entfernen.
- ⒼⒹ Remove protection film.
- Ⓕ Enlever le film de protection.

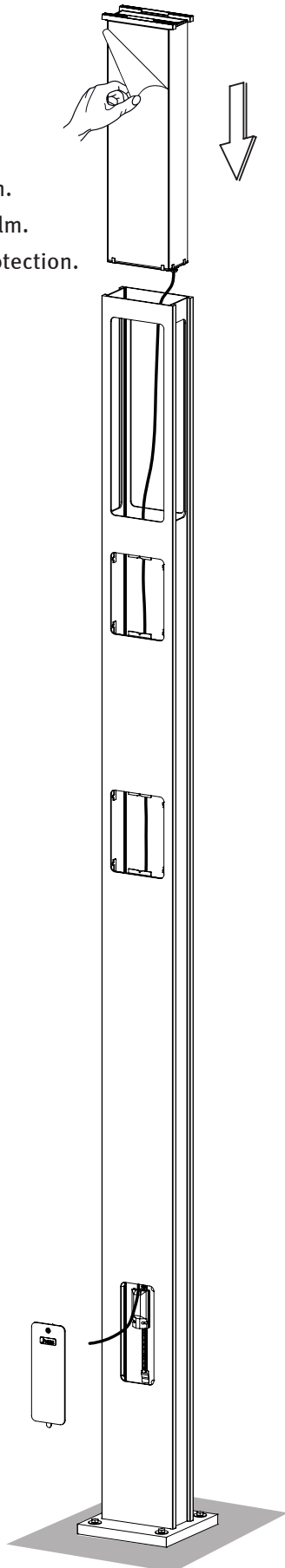

•• 5

1 Nm (4x)  
evenly

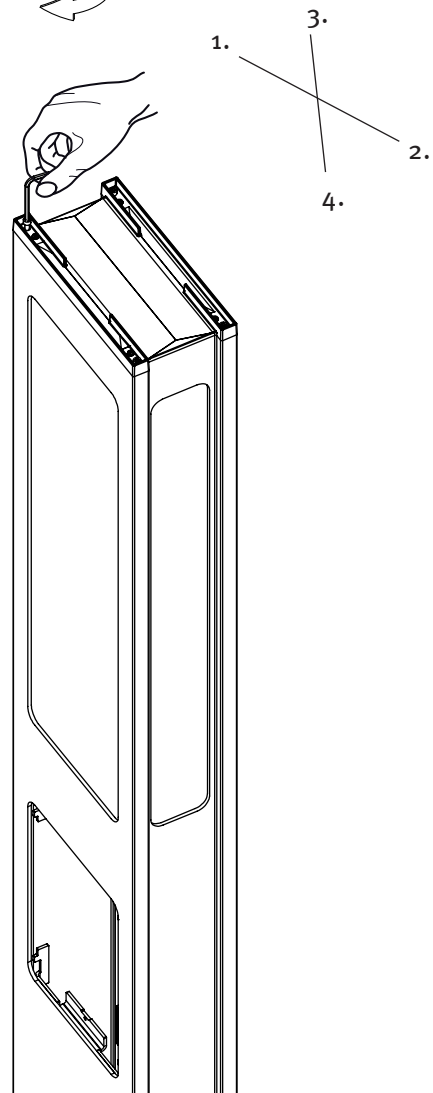



## 2.2 SPOT LIGHT

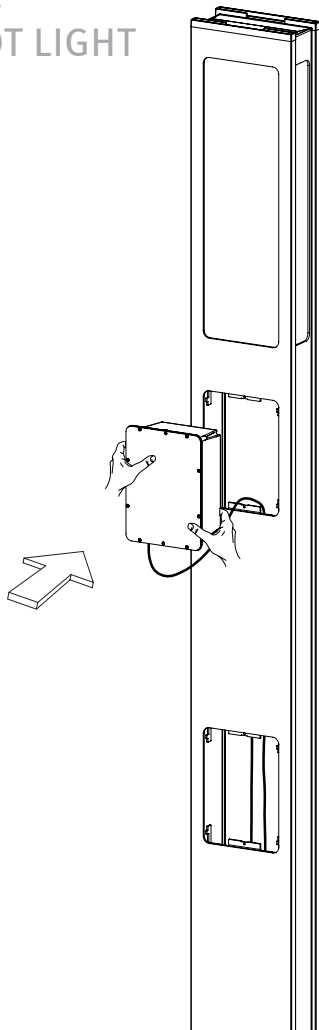

3 Nm  
2X

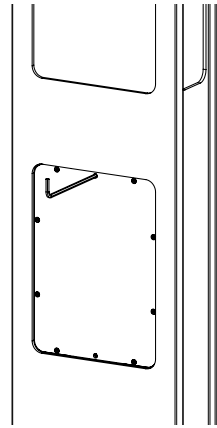

- Ⓓ Schutzfolie entfernen.
- ⒼⒷ Remove protection film.
- Ⓕ Enlever le film de protection.

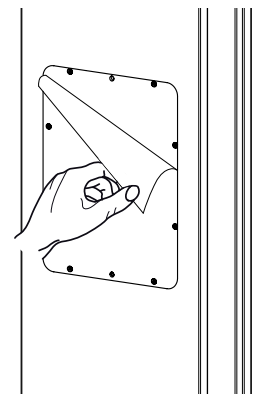

- Ⓓ Reflektor einstellen
- ⒼⒷ Adjust the reflector
- Ⓕ Ajustez le réflecteur

2,5

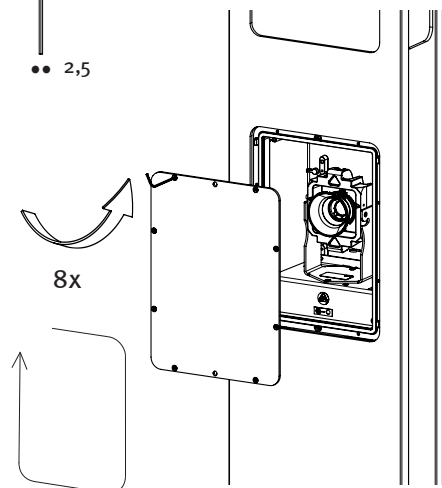

# 2.

Montage  
Mounting  
Montage

## 2.3 SPOT LIGHT

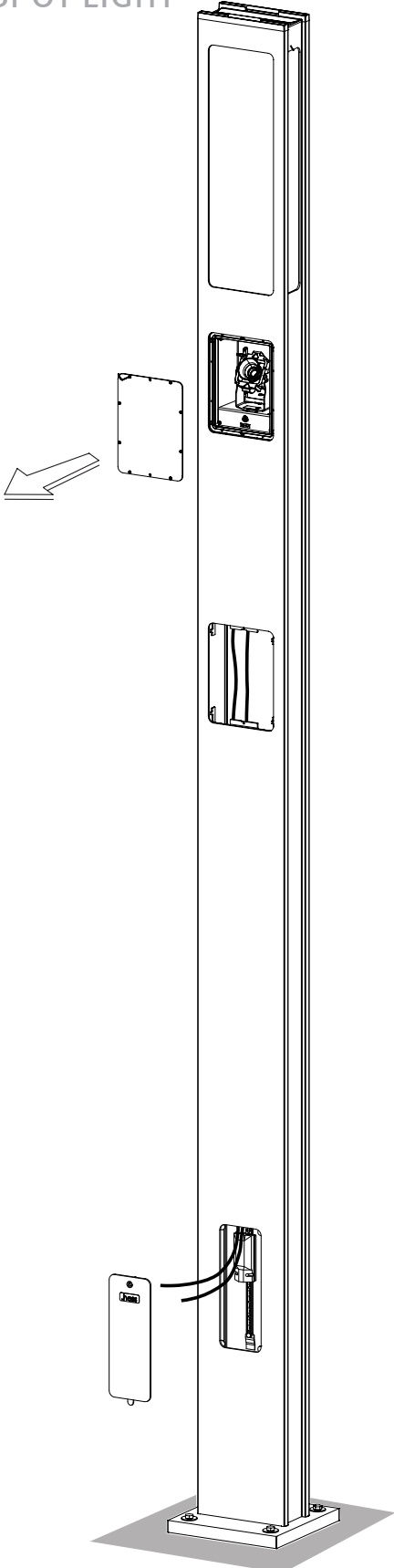

L3.1/L3.2  $\pm 20^\circ$   
L3.3  $\pm 35^\circ$

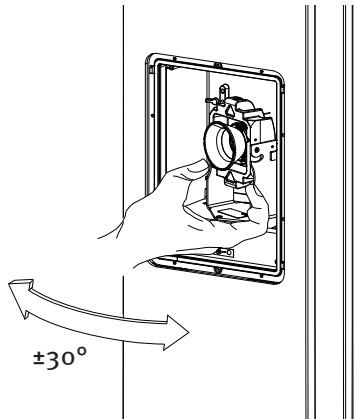
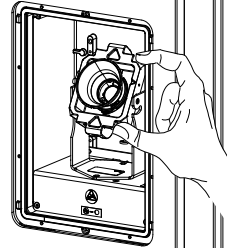

$\pm 30^\circ$

1Nm  
(8x)

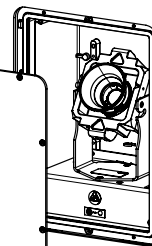
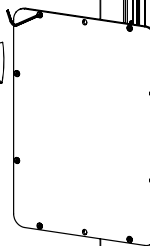
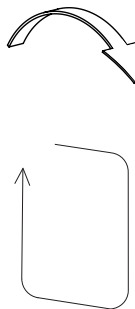

## 2.4 CCTV

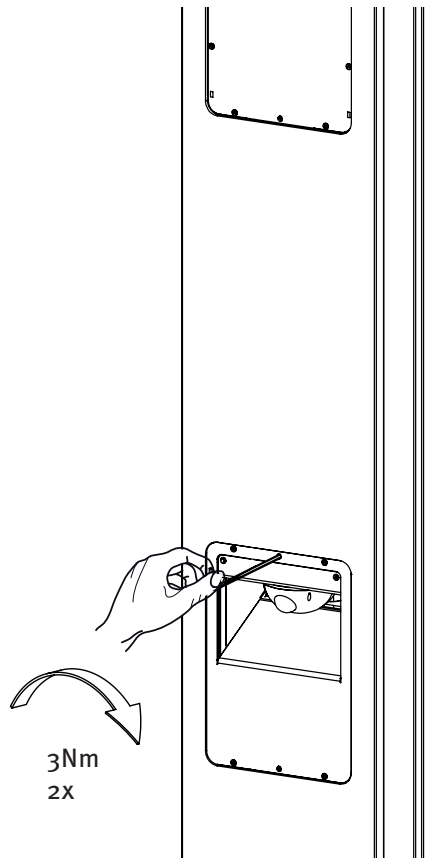
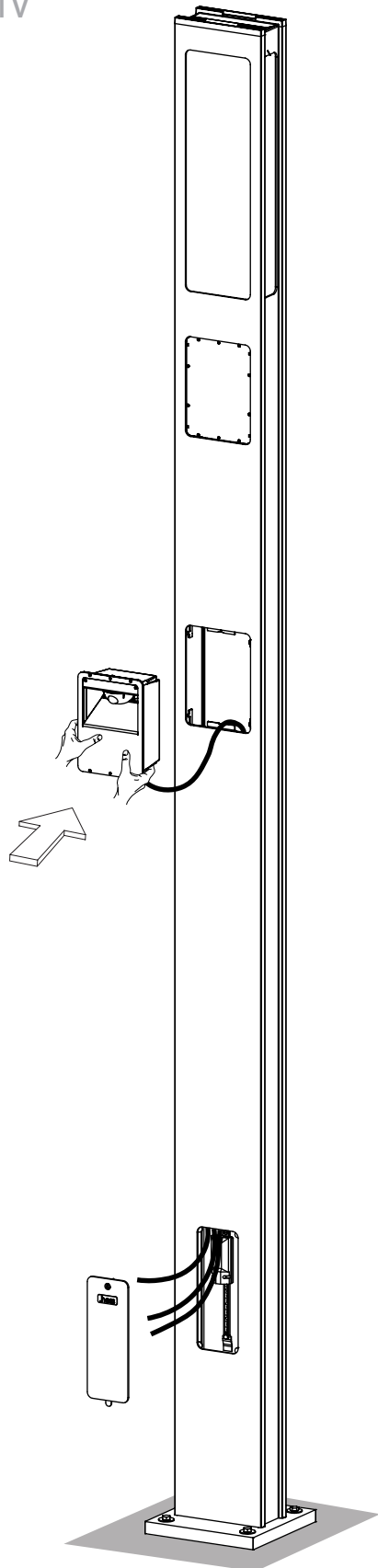

- Ⓓ Kamera einstellen.
- ⒼⒷ Set the camera.
- Ⓕ Régler l'appareil photo.

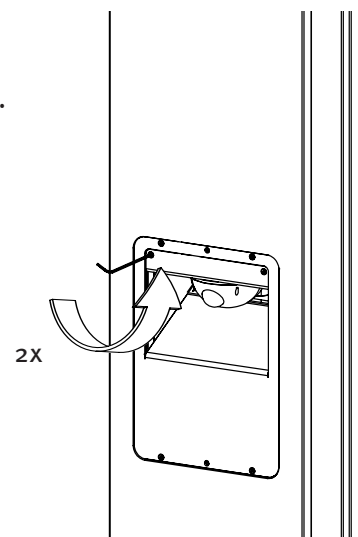

# 2.

Montage  
Mounting  
Montage

## 2.5 CCTV

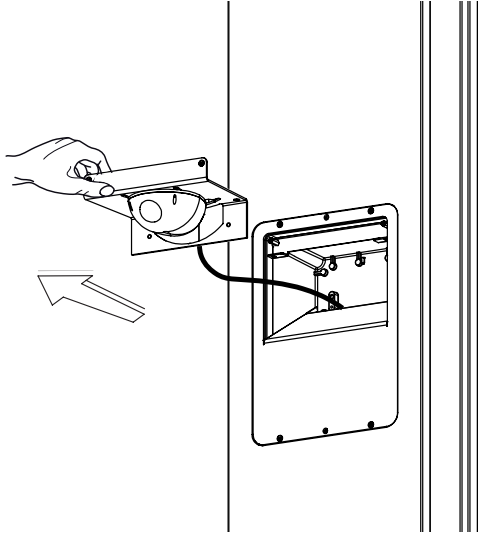

- Ⓓ Horizontale Einstellung.
- ⒼⒸ Horizontal adjustment.
- Ⓕ Réglage horizontal.

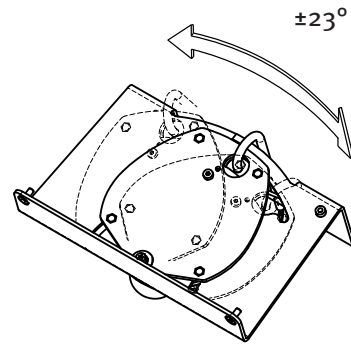

- Ⓓ Einstellung fixieren.
- ⒼⒸ Fix setting.
- Ⓕ Réglage fixe.
- ⒺⒶ Arreglo de configuración.
- Ⓘ Fissare l'impostazione.

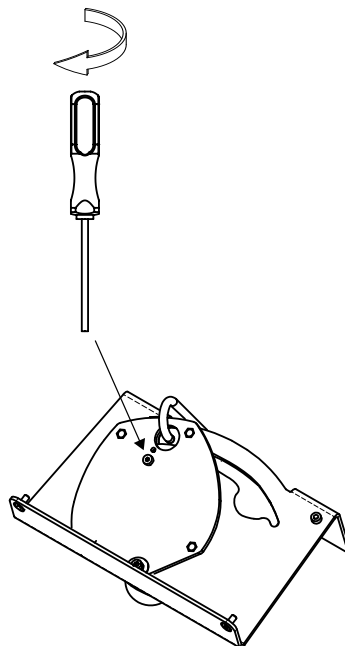

## 2.6 CCTV

- Ⓓ Vertikale Einstellung. Siehe auch Datenblatt CCTV.
- ⒼⒷ Vertical setting. See also data sheet CCTV.
- Ⓕ Réglage vertical. Voir aussi la fiche technique CCTV.

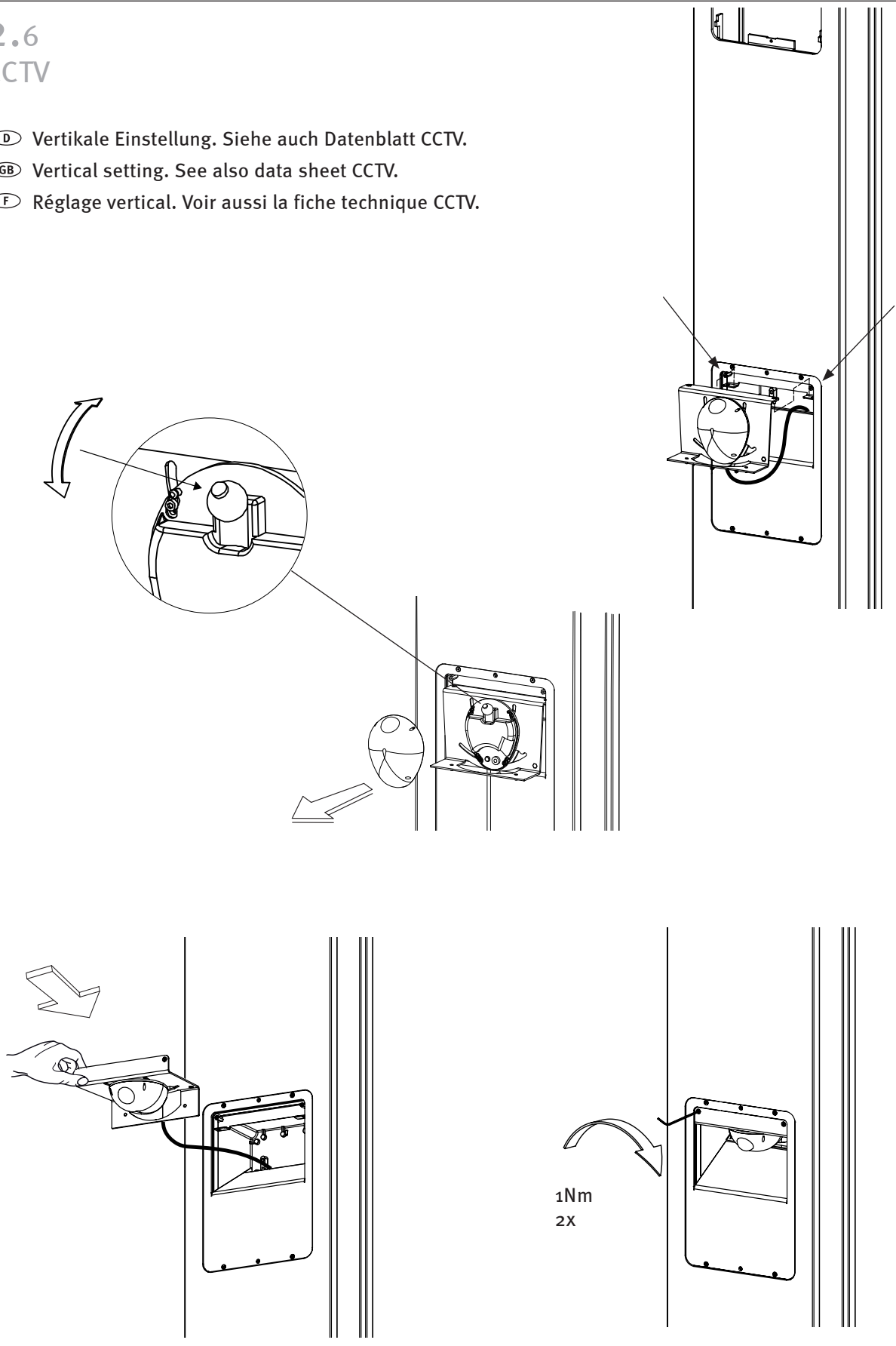

# 2.

Montage  
Mounting  
Montage

## 2.7 SPEAKER

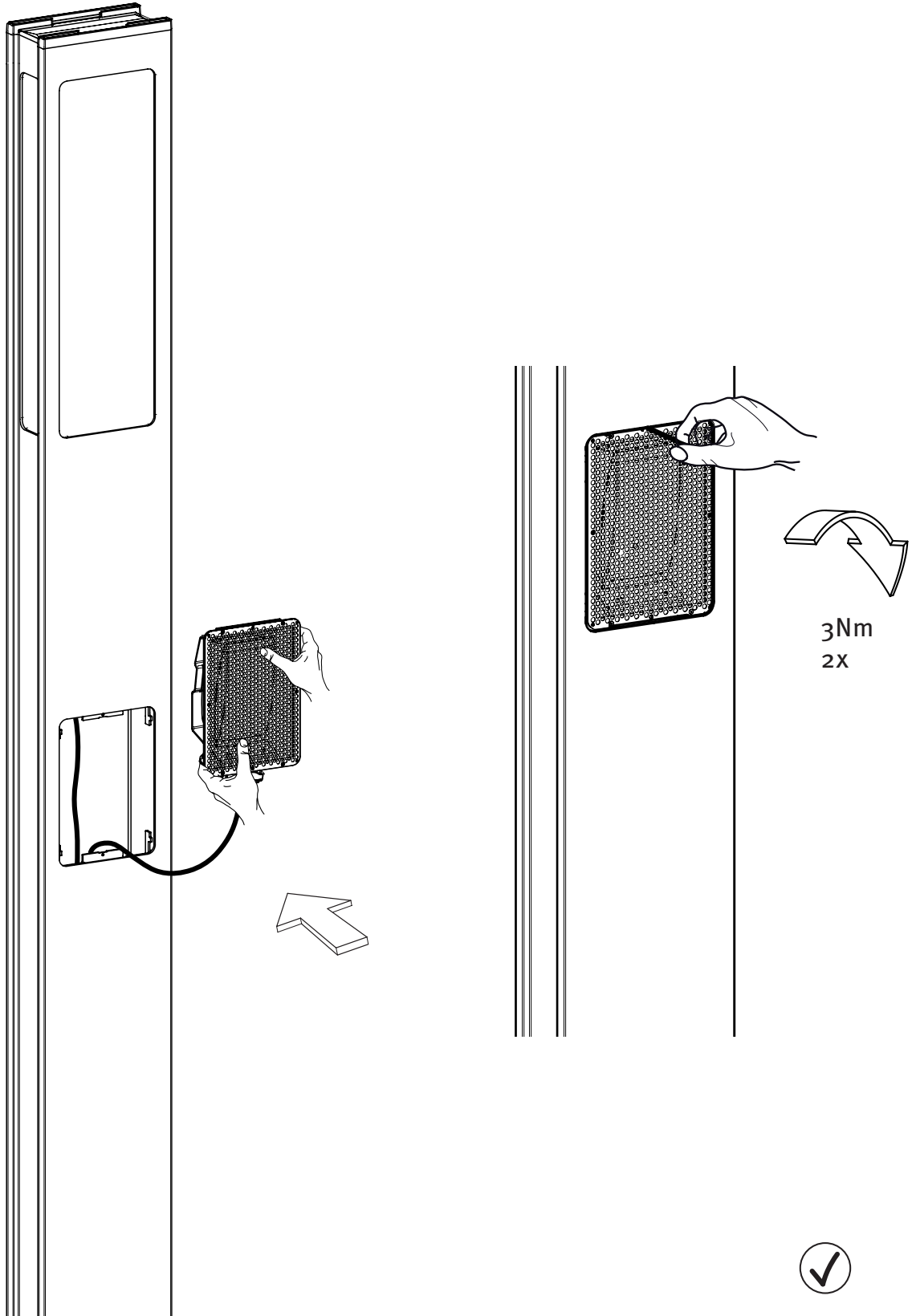

# 3.

Elektrische Verdrahtung  
Wiring  
Câblage électrique

**(D)** Der Kabelübergangskasten ist nicht im Lieferumfang enthalten, er muss VDE, ENEC und für die Montage auf C-Schienen zugelassen sein, sowie der Schutzklasse und Schutzart der Leuchte entsprechen. Die Schraubenanschlussklemmen müssen für das Auflegen der verwendeten Kabel zugelassen sein.  
Empfehlung: TYCO EKM 2040

**(GB)** The junction box does not come with the purchase of the luminaire. It must be VDE- and ENEC-approved. In addition, it must be approved for mounting to C-profile tracks and must be suitable for use with the respective luminaire's Protection Rating and Ingress Protection classifications. The screw terminals must also be suitable for the respective wiring that is used.  
Recommendation: TYCO EKM 2040

**(F)** Le boîtier de raccordement n'est pas inclus dans la livraison. Il doit être homologué VDE/ENEC ainsi que pour son montage sur des rails de transport et il doit correspondre à la classe électrique et à l'indice de protection du luminaire. Les bornes à vis doivent permettre d'appliquer des câbles utilisés.  
Recommandation: TYCO EKM 2040

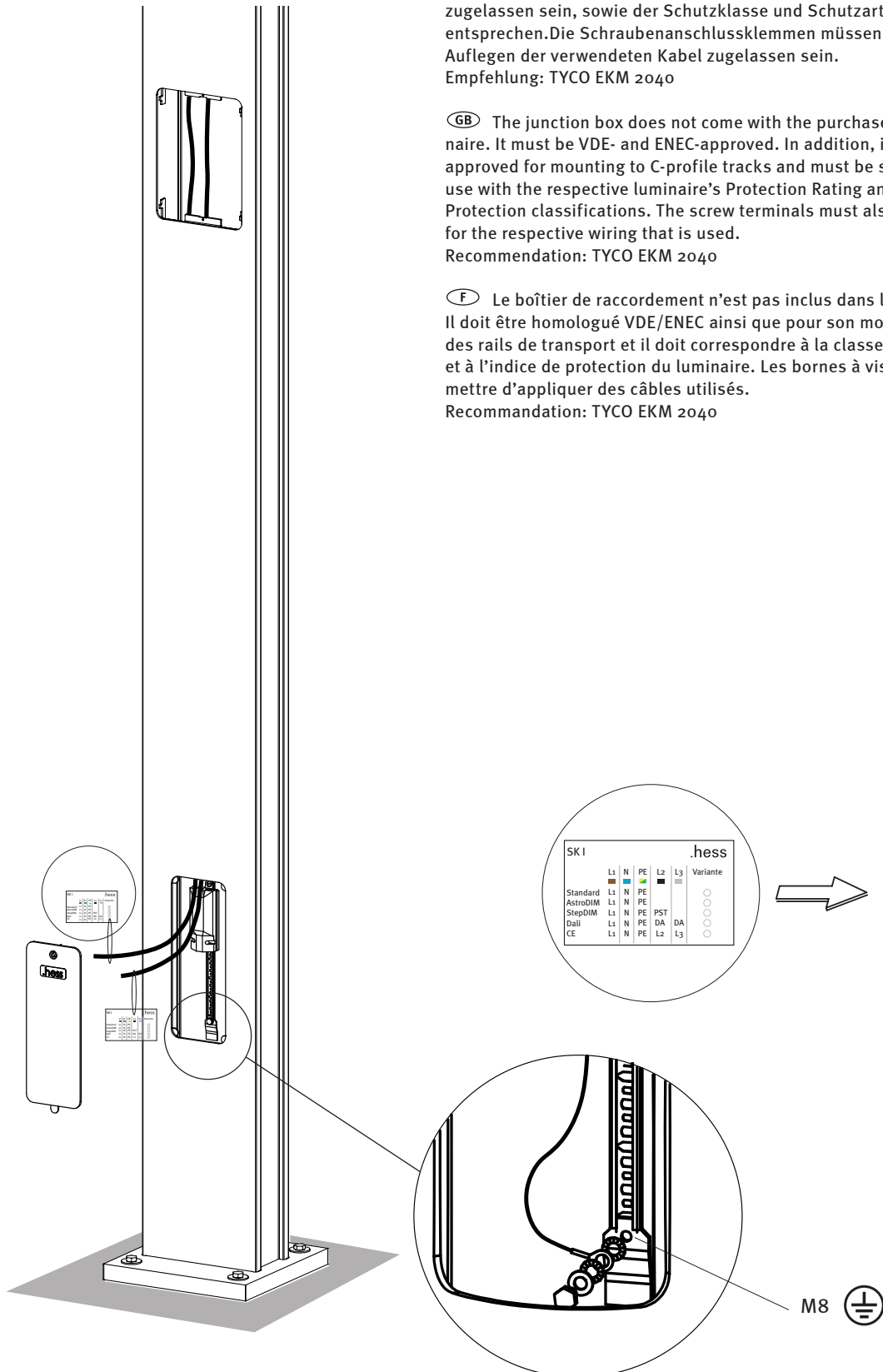

# 4.

# 4.

## Kabelbelegung Wiring diagram Positionnement brins de câble

- (D)** Schutzklasse I
- (GB)** Protection rating I
- (F)** Classe électrique I

Step DIM / Lineswitch  
Step DIM / Lineswitch  
Step DIM / Lineswitch

Ho5SS-F 5G1<sup>2</sup>



braun brown brun	grün/gelb green/yellow vert/jaune	blau blue bleu	schwarz black noir	grau grey gris
------------------------	---	----------------------	--------------------------	----------------------

- (D)** Schutzklasse II
- (GB)** Protection rating II
- (F)** Classe électrique II

Step DIM / Lineswitch  
Step DIM / Lineswitch  
Step DIM / Lineswitch

Ho5SS-F 4X1<sup>2</sup>

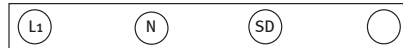

braun brown brun	blau blue bleu	schwarz black noir	grau grey gris
------------------------	----------------------	--------------------------	----------------------

- (D)** Schutzklasse I
- (GB)** Protection rating I
- (F)** Classe électrique I

Nachtabsenkung  
Night economy feature  
Réduction de puissance la nuit

Ho5SS-F 5G1<sup>2</sup>

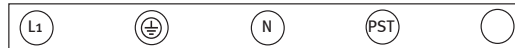

braun brown brun	grün/gelb green/yellow vert/jaune	blau blue bleu	schwarz black noir	grau grey gris
------------------------	---	----------------------	--------------------------	----------------------

- (D)** Schutzklasse II
- (GB)** Protection rating II
- (F)** Classe électrique II

Nachtabsenkung  
Night economy feature  
Réduction de puissance la nuit

Ho5SS-F 4X1<sup>2</sup>



braun brown brun	blau blue bleu	schwarz black noir	grau grey gris
------------------------	----------------------	--------------------------	----------------------

- (D)** Schutzklasse I
- (GB)** Protection rating I
- (F)** Classe électrique I

Dali  
Dali  
Dali

Ho5SS-F 5G1<sup>2</sup>

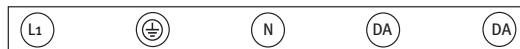

braun brown brun	grün/gelb green/yellow vert/jaune	blau blue bleu	schwarz black noir	grau grey gris
------------------------	---	----------------------	--------------------------	----------------------

- (D)** Schutzklasse II
- (GB)** Protection rating II
- (F)** Classe électrique II

Dali  
Dali  
Dali

Ho5SS-F 4X1<sup>2</sup>



braun brown brun	blau blue bleu	schwarz black noir	grau grey gris
------------------------	----------------------	--------------------------	----------------------

○ = nicht belegt / not allocated / non affecté



# 5.

Einstellmöglichkeiten "DIM Modul"  
 Settings "DIM Modul"  
 Possibilités de réglage "Module DIM"

## 5.1 StepDim

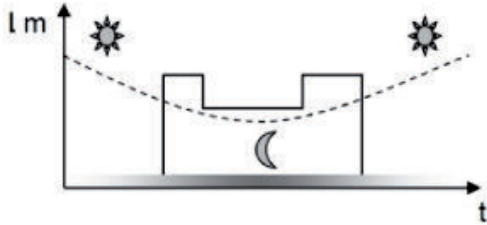

- (D)** Nachtabsenkung über Steuerleitung  
 Absenkung auf 30% / 50% / 70%  
 (weitere Stufen auf Anfrage)  
 Programmierung via Software  
 Serienmäßig integriert
- (GB)** Dims via a control lead  
 Dims to 30% / 50% / 70%  
 (For other dim levels, consult factory)  
 Programmes via software  
 Features above are standard
- (F)** Réduction de puissance nocturne avec ligne de commande  
 Réduction sur palier de 30% / 50% / 70%  
 (autres paliers sur demande)  
 Programmation via logiciel (software)  
 Intégrée en série.

## 5.2 AstroDim

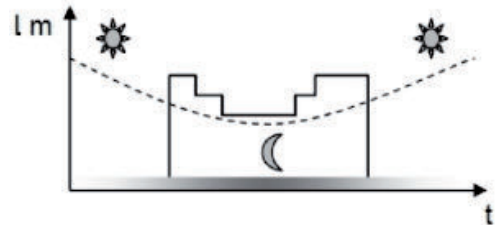

- (D)** Nachtabsenkung ohne Steuerleitung.  
 Dimmung auf 2 Absenkestufen möglich.  
 Programmierung via Software.  
 Theoretische Mitternacht wird selbständig ermittelt.  
 Serienmäßig integriert.
- (GB)** Dims without using a control lead.  
 2 stages are possible.  
 Programmes via software.  
 Automatically determines when midnight is.  
 (approximate)  
 Features above are standard.
- (F)** Réduction de puissance nocturne sans ligne de commande  
 Gradation d'éclairage possible sur 2 paliers de réduction.  
 Programmation via logiciel (software)  
 L'heure de minuit théorique est déterminée de façon indépendante.  
 Intégrée en série.

## 5.3 Dali

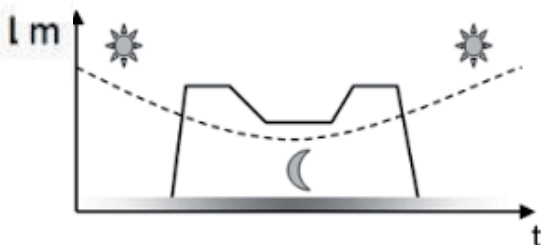

- (D)** Ansteuerbar über diverse Telemanagementsysteme (Zigbee, Powerline, ...)  
 Dimmung von 10% bis 100%  
 einstellbar (Kunde)  
 Serienmäßig integriert
- (GB)** Operable and controllable in various communication networks  
 (Zigbee, Power line, etc.)  
 Dim levels from 10% to 100% possible (customer-set)  
 Features above are standard
- (F)** Pilotable au moyen de divers systèmes de management à distance (Zigbee, Powerline, ...)  
 Gradation d'éclairage réglable de 10% à 100% (client)  
 Intégrée en série

# 6.

Wartung  
Maintenance  
Entretien



## 6.1 TOP LIGHT

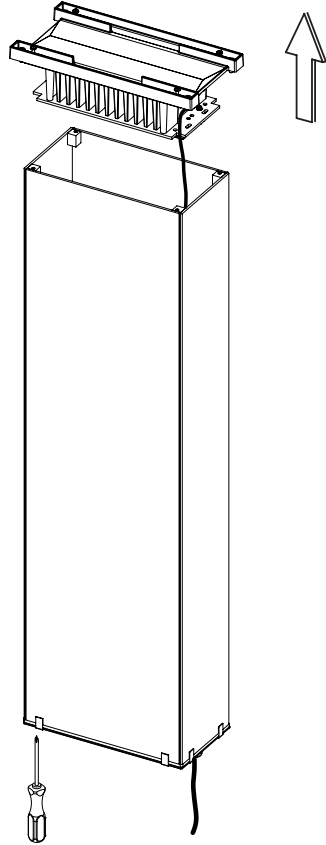
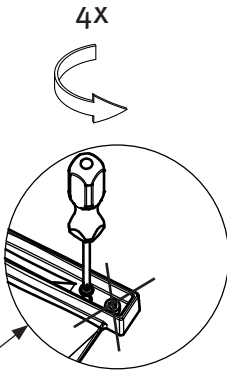
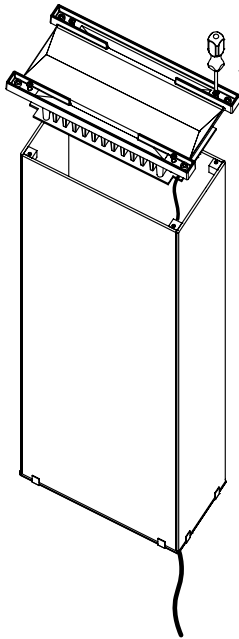
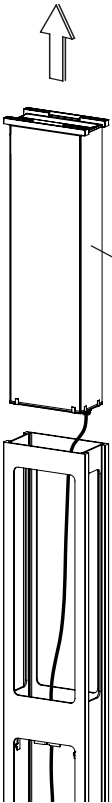

alt  
old  
ancien

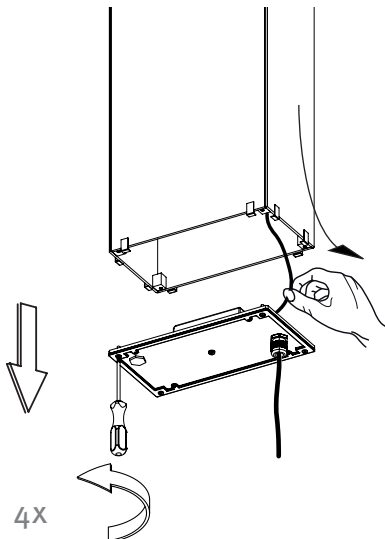
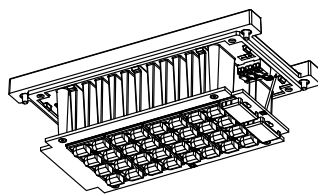
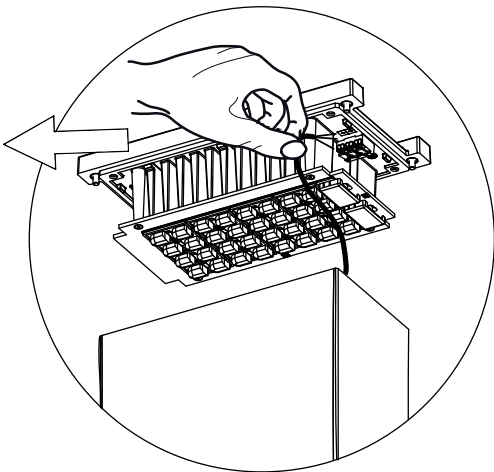

# 6.2

alt  
old  
ancien

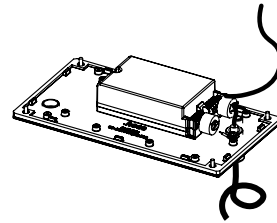
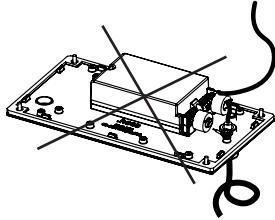

neu  
new  
nouveau

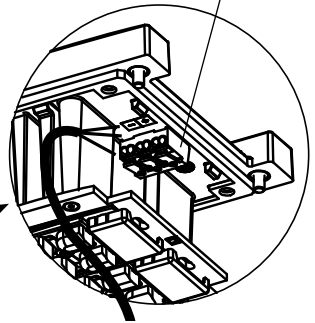
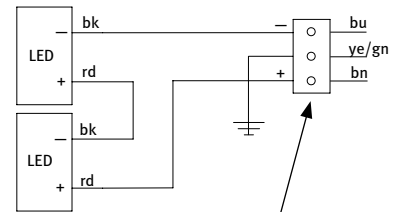
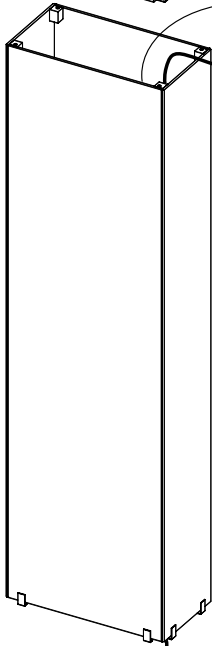
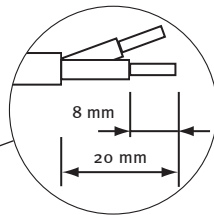
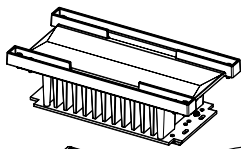

neu  
new  
nouveau

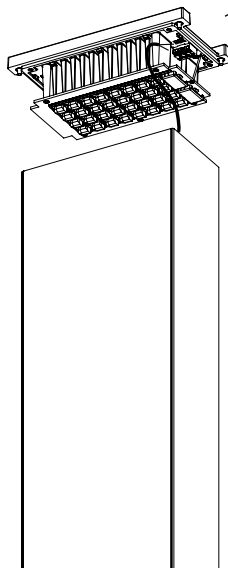
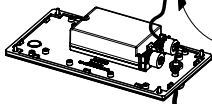

# 6.

Wartung  
Maintenance  
Entretien

## 6.3

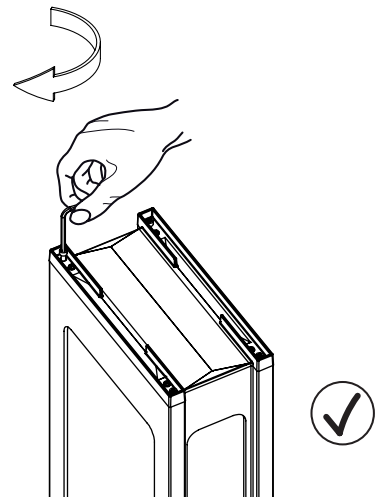
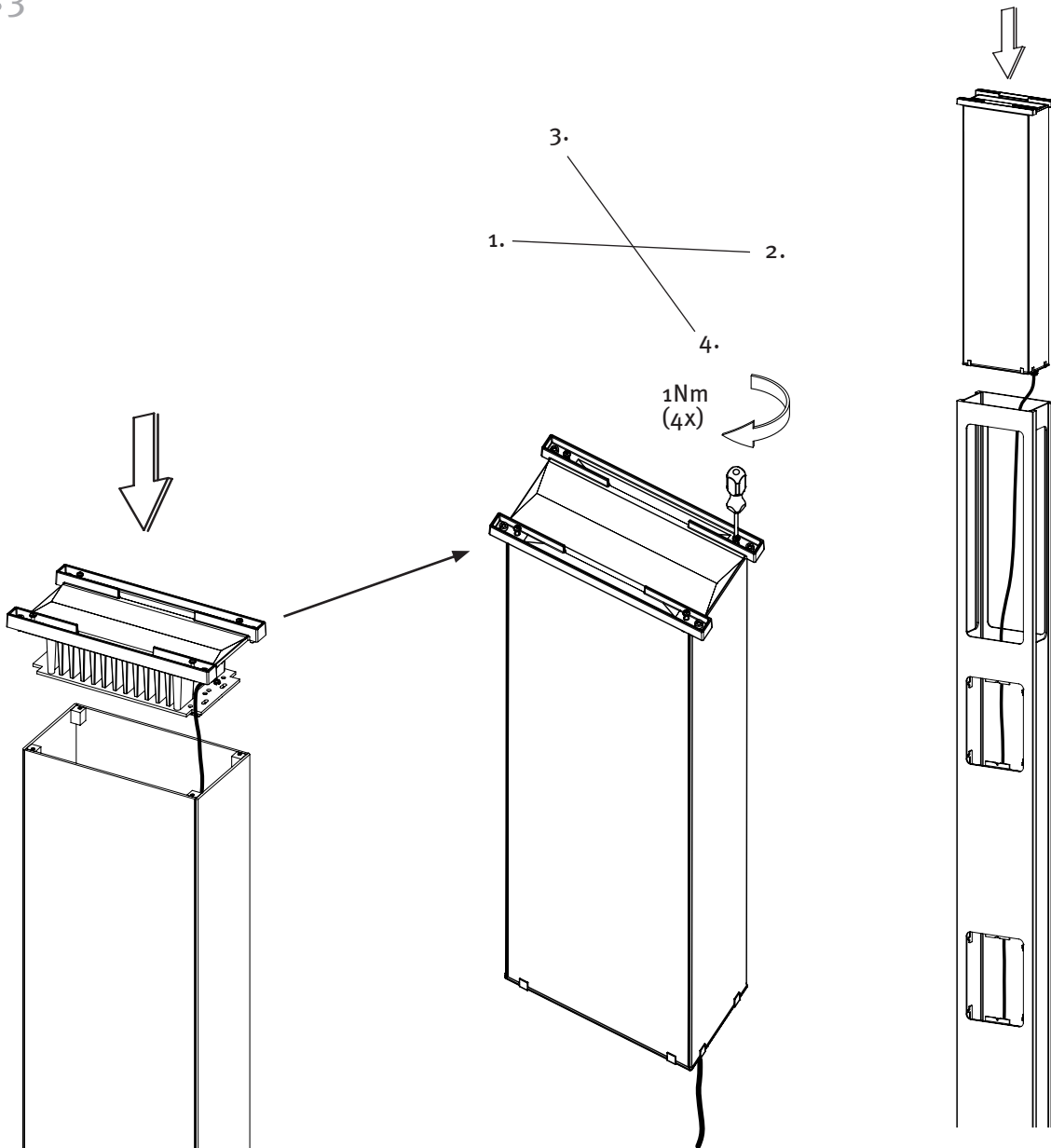

# 6.4 SPOT LIGHT

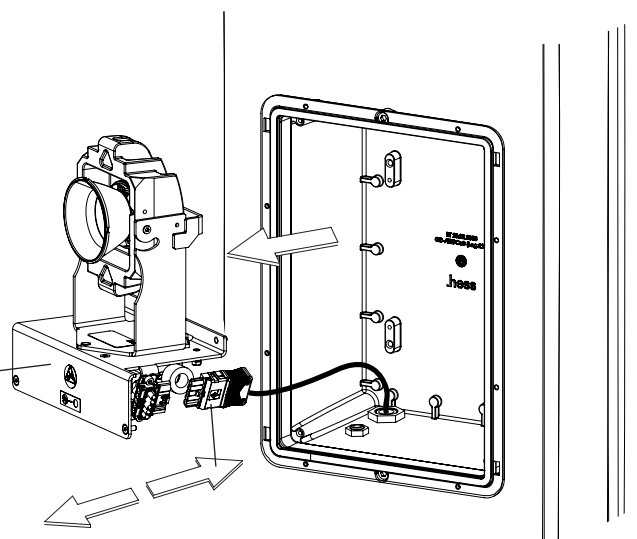
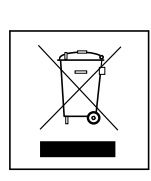
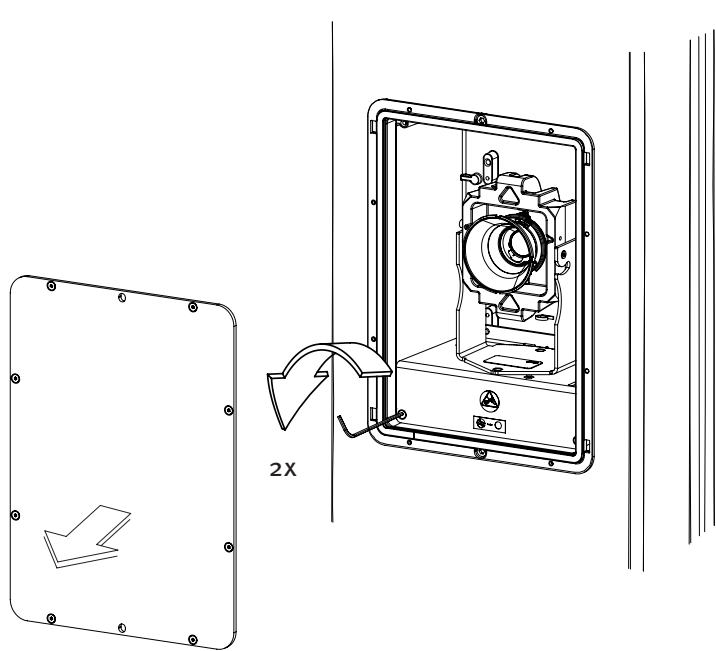
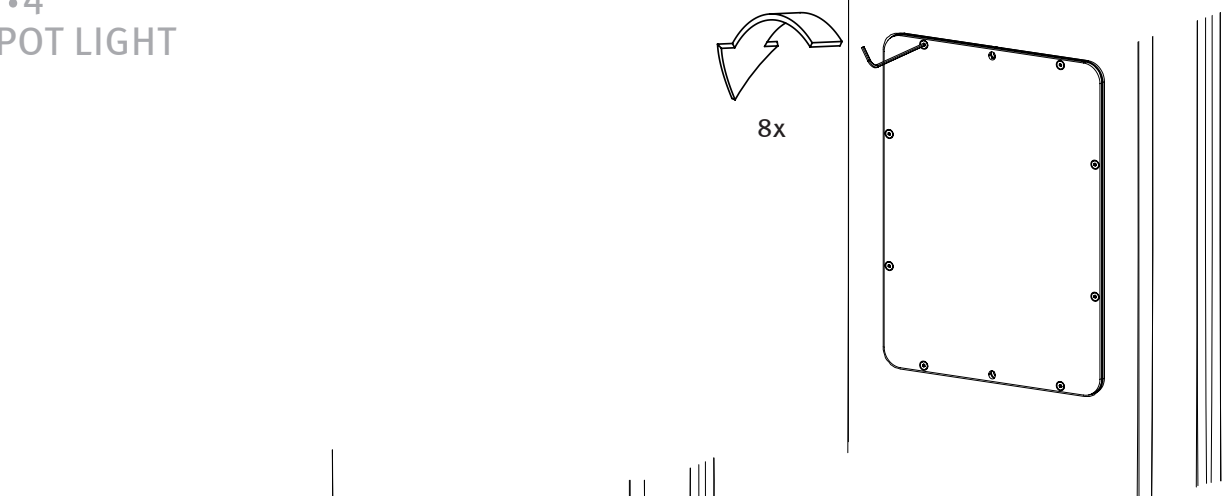

# 6.

Wartung  
Maintenance  
Entretien

## 6.5

neu  
new  
nouveau

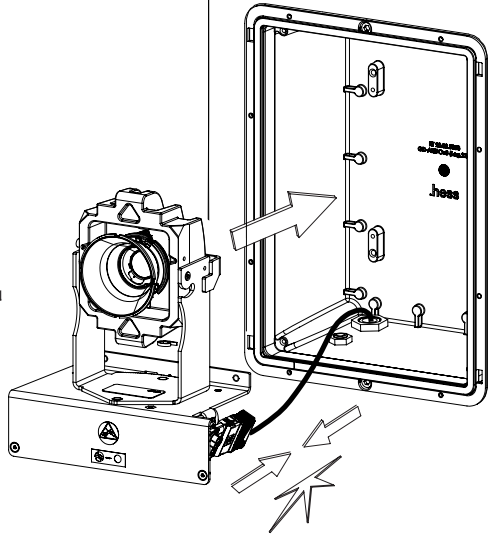

L3.1/L3.2  $\pm 20^\circ$   
L3.3  $\pm 35^\circ$

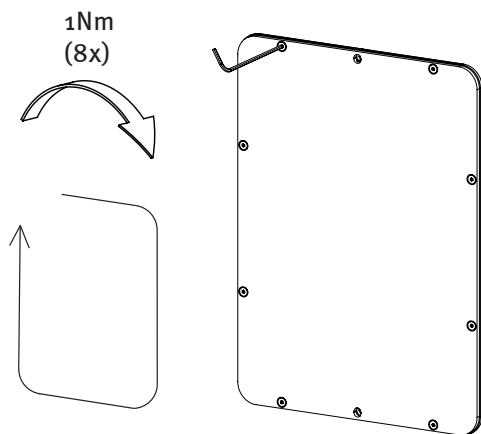
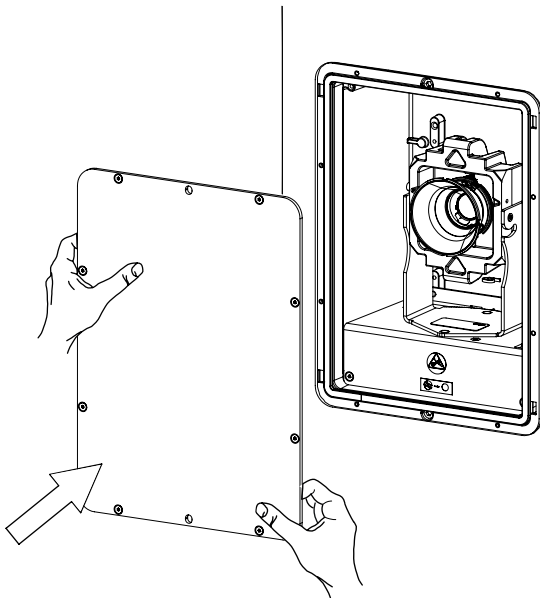
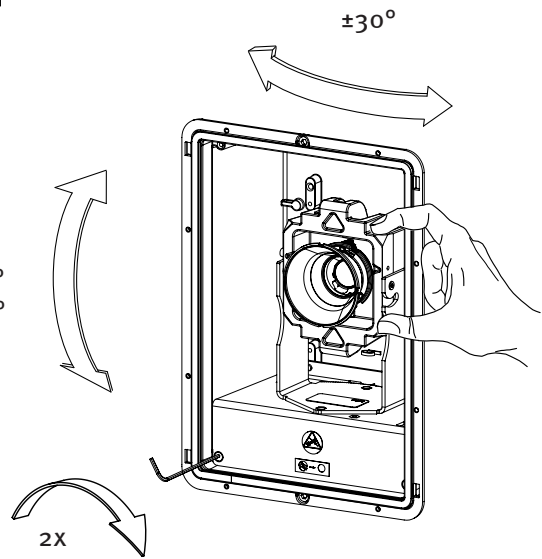

# 6.

Nachrüsten  
Retrofitting  
Rééquipement



## 6.6

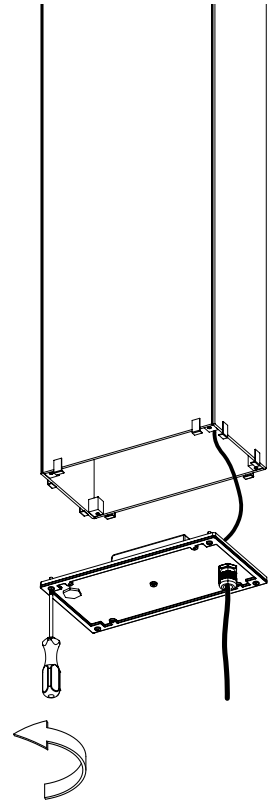
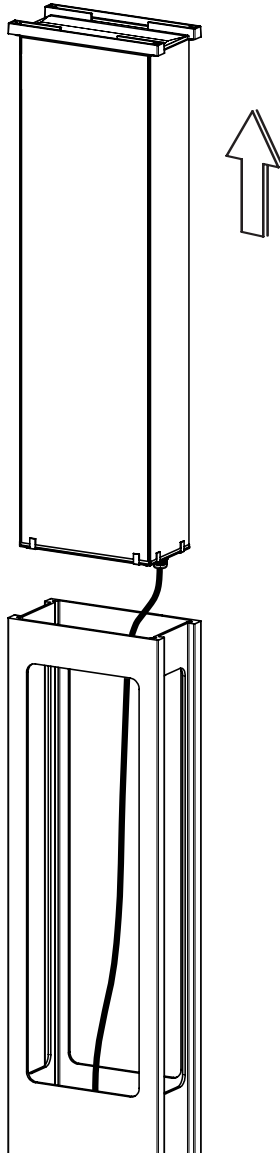
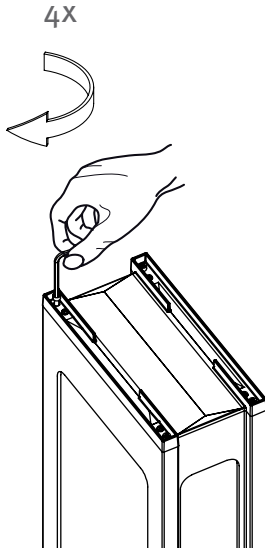

Wichtige Hinweise  
Important Information  
Consignes importantes



# 6.

Nachrüsten  
Retrofitting  
Rééquipement

## 6.7

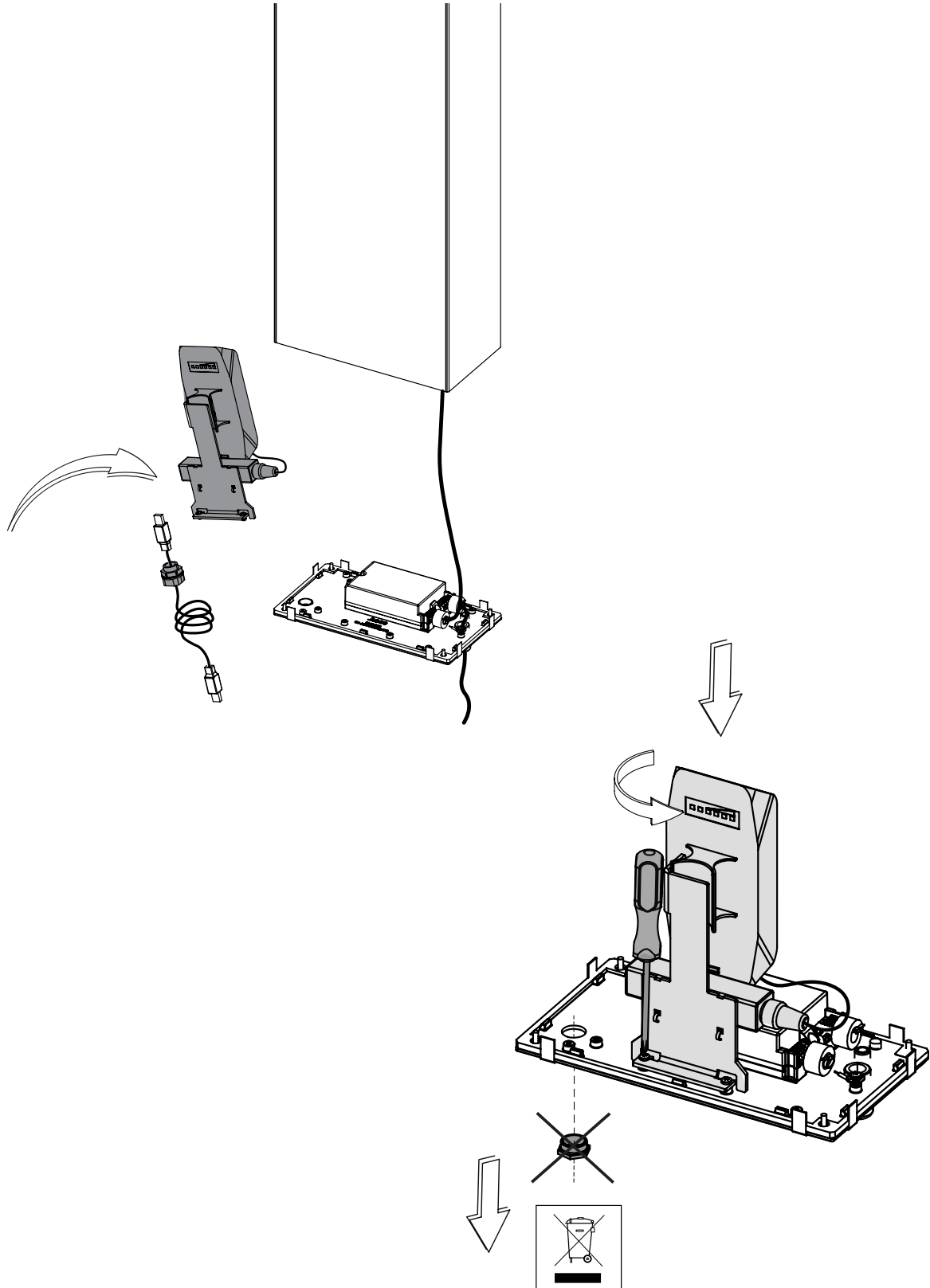



6.8

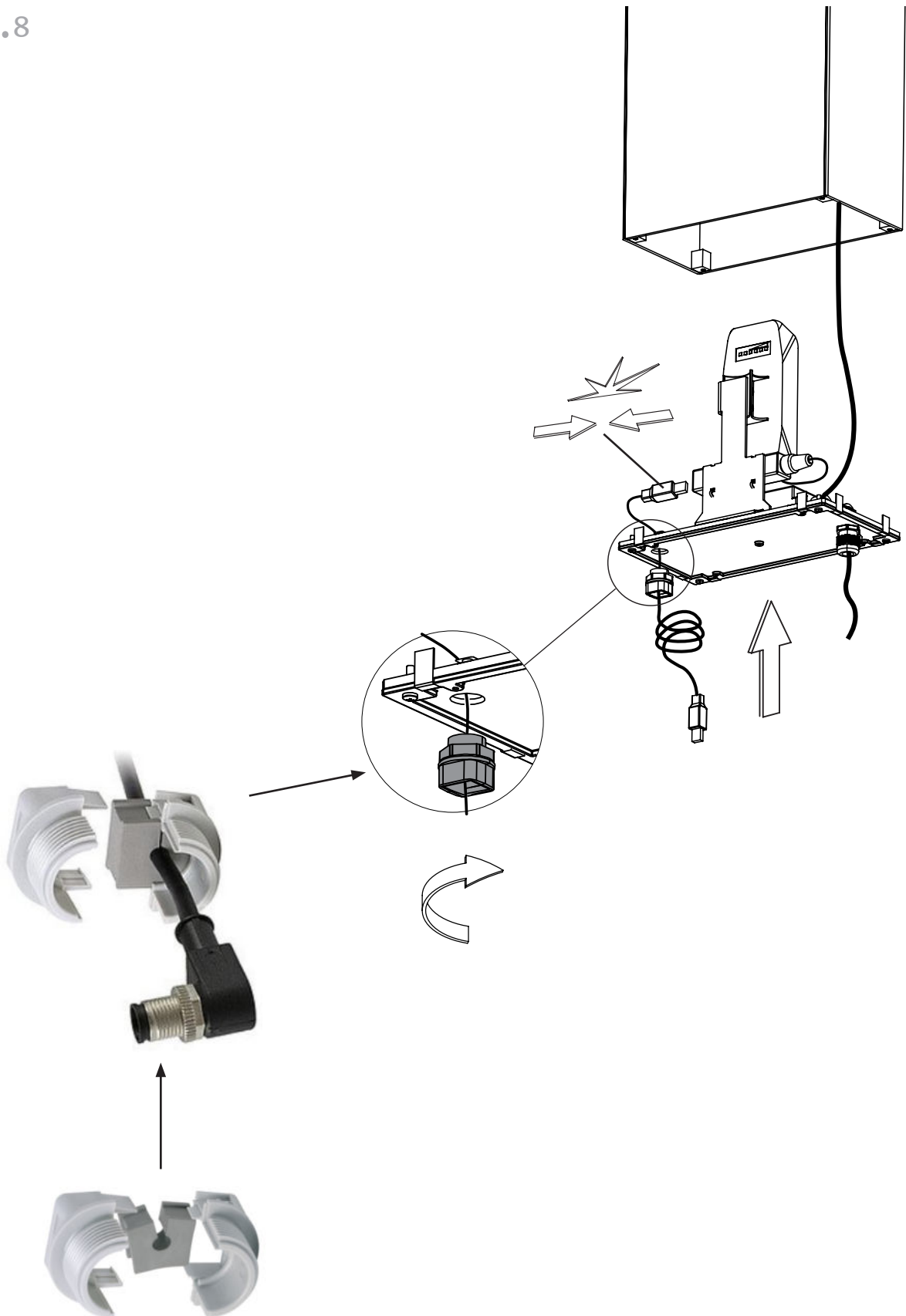

6.

Nachrüsten  
Retrofitting  
Rééquipement

6.9

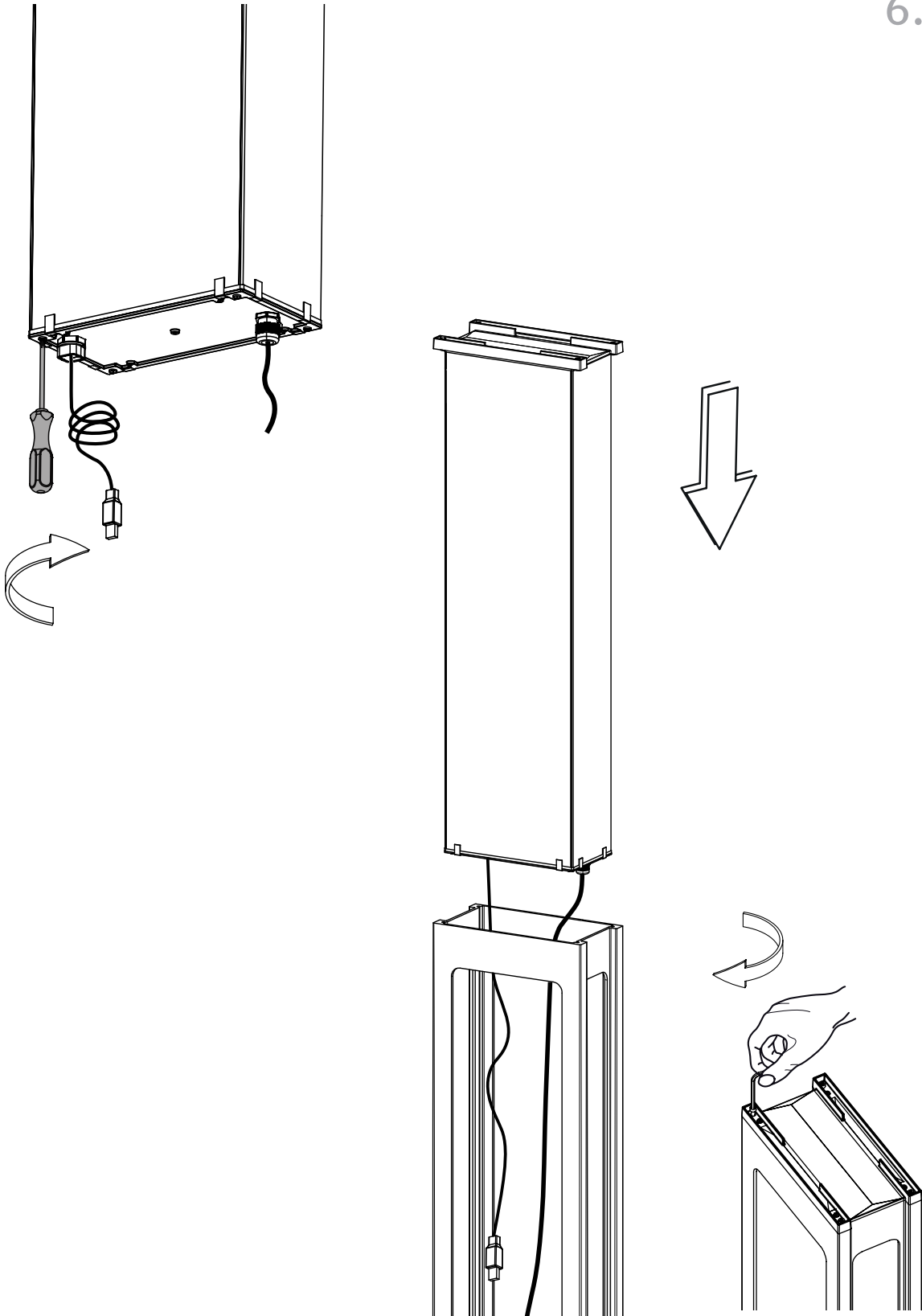

7.

Dickschichtlackierung  
extra thick coat of varnish  
laquage à couche épaisse

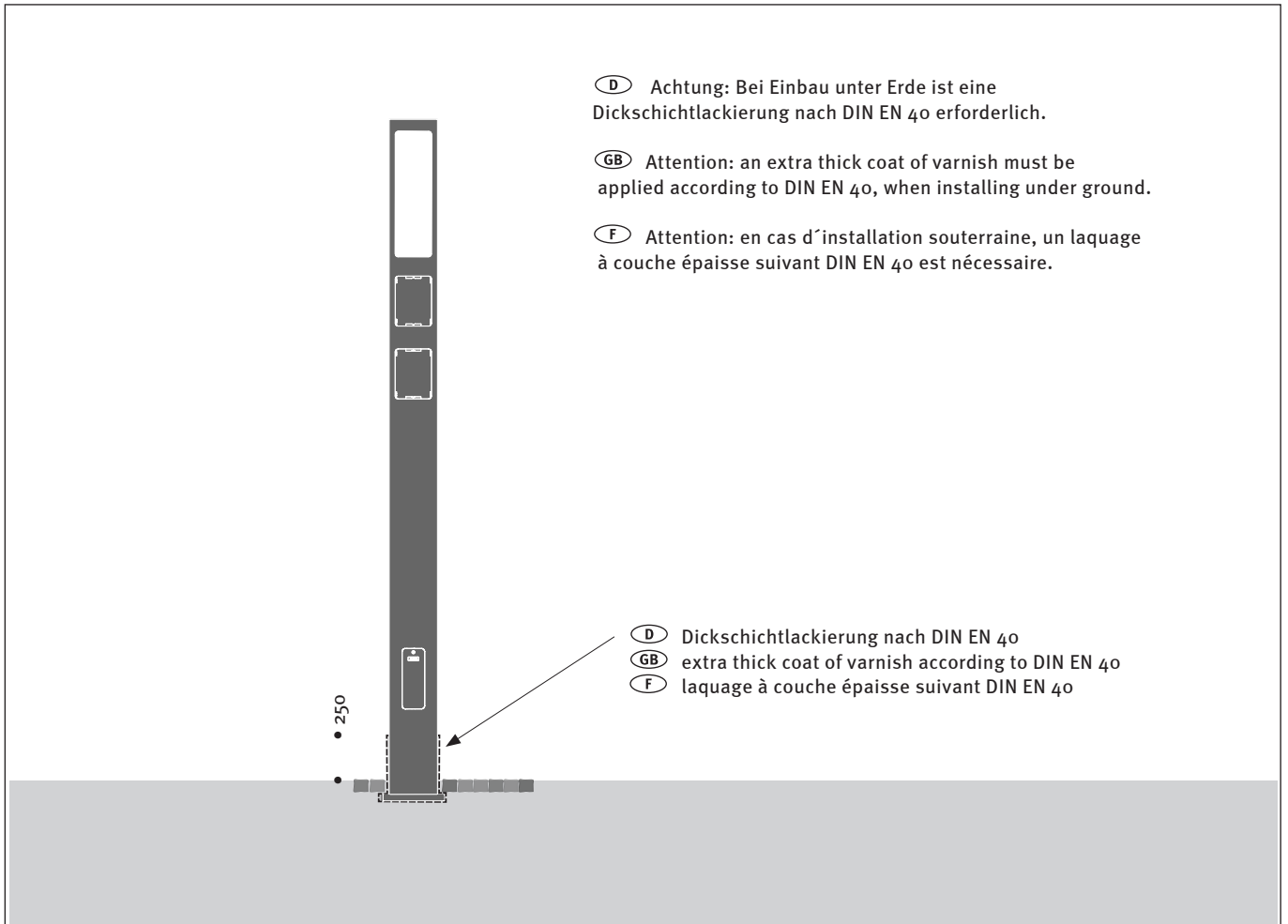

8.

(D) Einbauempfehlung Bewegungsfuge.  
(GB) Recommendation expansion joint.  
(F) Joint de dilatation recommandé.

Wichtige Hinweise  
Important Information  
Consignes importantes

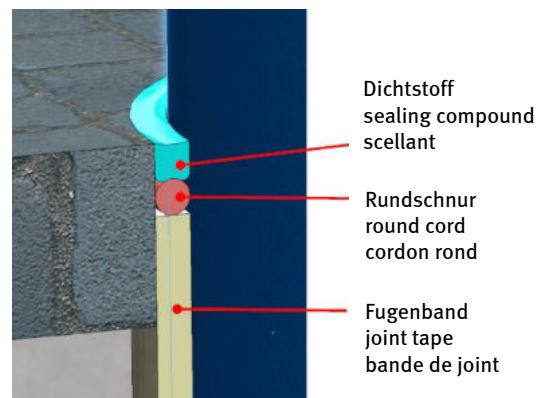
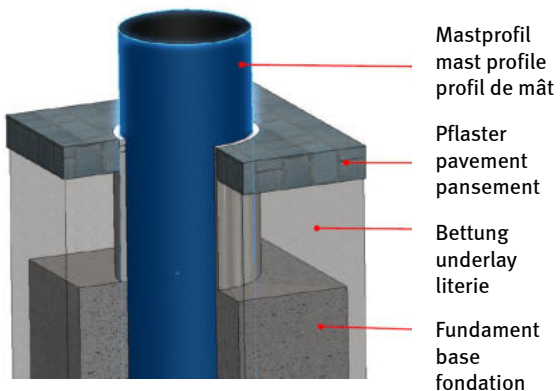

Hess GmbH  
Licht + Form  
Lantwattenstraße 22  
D-78050 Villingen-Schwenningen  
Tel. +49 7721 / 920-0  
Fax +49 7721 / 920-250  
info@hess.eu  
www.hess.eu